

Detroit Engineered products (DEP), is an engineering services, product development, software development, consulting and talent acquisition company. Since its inception in 1998 in Troy, USA, DEP is now a global company with footprints in Europe, China, Korea, Japan, and India. DEP uses the accelerated and transformed product development process, accomplished by utilizing our proprietary platform, DEP MeshWorks, which rapidly reduces the development time of products for all segments. The MeshWorks platform delivers tool sets that accelerate virtual validation across all stages of powertrain development for both conventional and electric models.

DEP supports programs for all major industries and deliver outcomes that result in time reduction from a few weeks to a few months, and by expanding the value of projects from a few thousand dollars to multi-billion dollar projects. Our clients depend on DEP to provide anything from niche services to complete product development support. We support clients across start-ups to multi-billion dollar companies and OEMs including Government & Defense organizations. We have supported sole proprietorship companies to help them grow and expand their territories into an established organization by bringing their product development dreams to life. We work across policies and certifications in the global market. Currently, design & development for an entire e-Vehicle for a major Defense Supplier is being done in an ITAR(International Traffic in Arms Regulations) environment, meeting regulatory compliance for the US.

DEP has a comprehensive range of solutions for organizations in the mobility sector to quickly develop EVs and convert their existing models to electric vehicles. We offer a full range of Electrification services, including benchmarking, reverse engineering, motor design and development, testing and validation, battery design and development, electronic controller, etc.



Smarter solutions. Realized.

E-MOBILITY SOLUTIONS

Benchmarking

Comprehensive benchmarking analysis, giving customers an edge on future product development

Reverse engineering

Complete dismantling and re-assembly instructions including detailed images and PowerPoint

Motor design and development

Design & development based on the increasing dependency of electrical components and overall complexity, coupled with a short design cycle

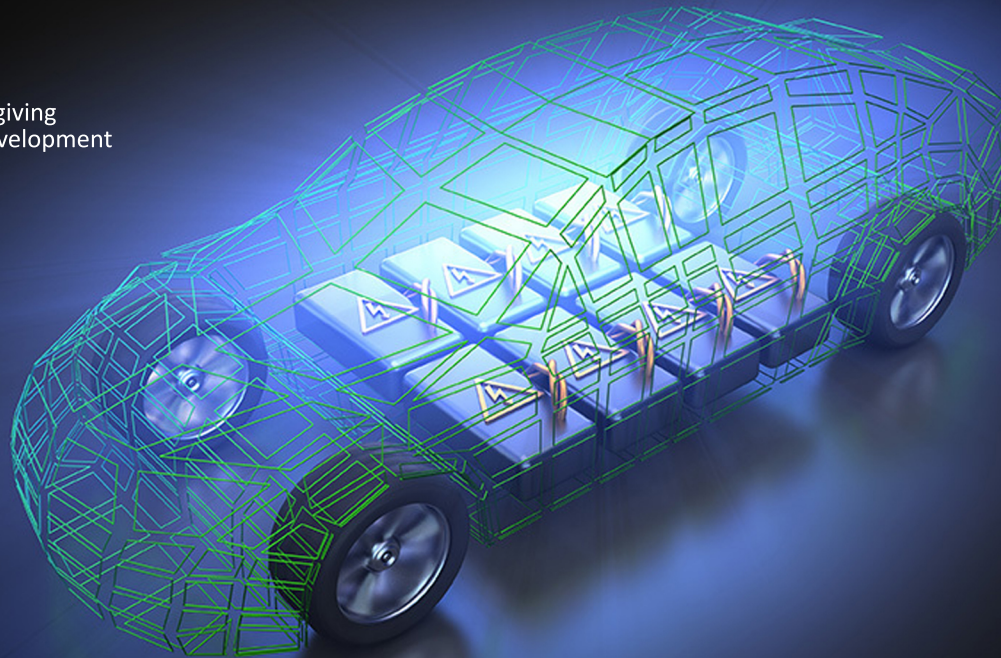

Testing and Validation

Leverage the results from test validation to quickly and decisively arrive at accurate results

Battery Design and Development

Complete Battery Pack Modeling for Safety, Durability and NVH

Electronic Controller development

Efficient and precise approach to manufacturing on-time

Conversion of Conventional vehicle to Electric

Specialized CAE tool ConceptWorks, for conceptual EV BIW Development:

- Special Member/joint Creation without any CAD
- Flange Adjustments
- Special member creation functions: Quick Bead, Boss, Fillet Holes and split members
- BSO Inner Parts Features: Roof Rail Inner, Header, Roof Bow, B-Pillar Inner
- Full Vehicle Simulation: Crash, NVH & Durability
- Design, Simulation & Analysis for Electric Vehicle Systems & Components



Adding floor pan, wirefall, etc.

FE model conversion done in 2 days



Battery & Motor Simulation and Testing

- Motor design and development
 - Reverse engineering
 - Motor drive design
 - EMI Analysis
 - EMA and Motor performance
 - Thermal Analysis
 - Structural Analysis: NVH, Durability, etc.
 - IM/PM Motor sizing and efficiency
- Holistic battery design and development – Integrated battery system analysis
 - Electrochemical Analysis
 - Cell Level ECM Analysis
 - Thermal Analysis
 - Cell Charging and Discharging
 - Module Level Analysis
- Holistic battery design and development – Integrated battery system analysis
 - Structural and Thermal Analysis including Battery
 - Cooling Simulation
 - Battery Aging Mechanisms

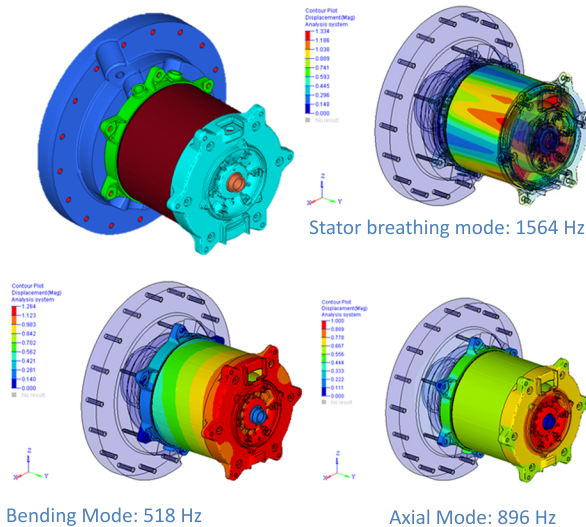

Electronic Controllers Design & Simulation

- Electronic Product development services
- Design Analysis:
 - Circuit Schematic Design
 - PCB Design based on schematic
 - Gerber Files Generation
 - Electrical & Functional Testing services of the designed PCB
 - PCB level - Multi Board & system-level design analysis
- Hardware & Software Testing (Analog & Digital)
 - Hardware Re-Engineering
 - Reverse Engineering
 - Electronic Design Support Services
- Test Engineering
 - Product Verification and validation
- Mechanical Engineering:
 - Detailed Mechanical Design
 - Design Documentation
 - Customized prototype creation
- Embedded System Development
 - Data Communication Support- Ethernet, CAN protocol

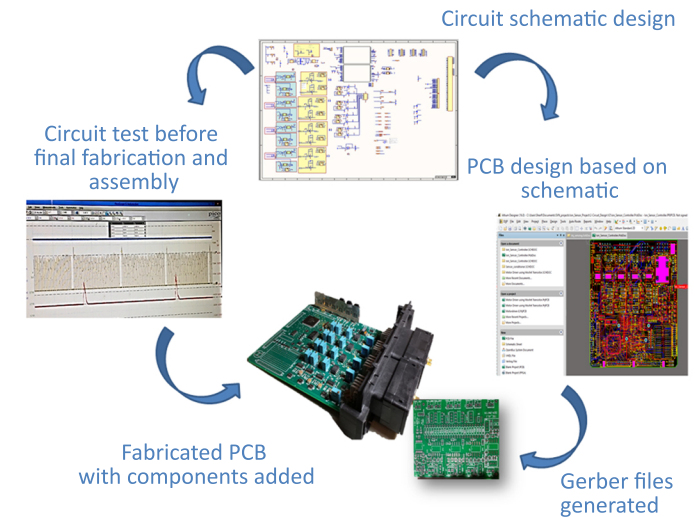

Email us: email@depusa.com | Visit our Website: www.depusa.com

USA: MI (HQ) : Detroit Engineered Products, 850 East Long Lake Road, Troy, MI 48085, USA. | Phone: +1-248-269 7130

INDIA : DEP India Pvt. Ltd., #2/86, 7th Avenue, Ashok Nagar, Chennai – 600 083, India | Phone: +91 44 42141453

BANGALORE : DEP India Pvt. Ltd., 4th Floor, Gamma Block, Sigma Soft Tech Park, HAL – Whitefield Main Rd, Bangalore 560066